

# Millennium



Pastry LX - H135

Gelato LX - H135

# Millennium

Pastry

**H** 117 (ST) -135 (LX-ST)

**P** 110

**L** 120 • 170 • 220

VP RV

**Installazione**

- Plug-in
- Remoto (optional)

**Configurazione**

2 mensole (LX/ST H135)

**Temperatura**

-1/+10 °C

**Refrigerante**

R290

**Refrigerazione**

Ventilata

**Compressore**

Ermetico

**Sbrinamento**

Fermata compressore

**Classe Climatica**

3

**Vetro superiore**

Singolo

**Vetro frontale**

Singolo riscaldato

**Vetri laterali**

Doppio (camera) riscaldato

**Apertura anteriore**

- Apertura servoassistita verso l'alto (LX)
- Apertura verso il basso (ST)

**Chiusura posteriore**

Scorrevoli in Plexiglass (ST H117- LX/ST H135)

**Piano di servizio**

Acciaio inox

**Illuminazione**

Led 4000 K

**Movimentazione**

Ruote pivotanti con freno e piedini regolabili in altezza

**Installation**

- Plug-in
- Remote (optional)

**Configuration**

2 shelves (LX/ST H135)

**Temperature**

-1/+10 °C

**Refrigerant**

R290

**Refrigeration**

Ventilated

**Compressor**

Hermetic

**Defrost**

Off cycle

**Climate class**

3

**Upper glass**

Single

**Front glass**

Heated single

**Side glasses**

Heated double

**Front opening system**

- Servo bottom-up opening system (LX)
- Bottom-down opening system (ST)

**Rear closing system**

Plexiglass sliding doors (ST H117- LX/ST H135)

**Work top**

Stainless steel

**Lighting**

Led 4000 K

**Equipment handling**

Swivel casters with brake and height adjustable feet and height adjustable feet

**Colori disponibili**

Available colours

**Pannello frontale / Fianchi laterali / Griglia inferiore**

Front panel / Side panels / Bottom front grid

Bianco RAL 9003

# Millennium

Pastry



Pastry  
LX - H135



Pastry  
ST - H135

ST - H117

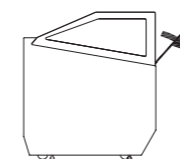

ST - H135

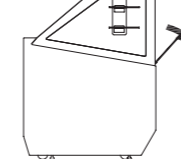

LX - H135

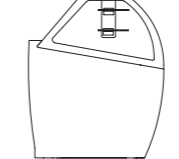

Millennium			120	170	220
Pastry					
<b>Dimensioni esterne (LxPxH)</b> External dimensions (LxDxH)	H117	ST	1165x1055x1175 mm	1660x1055x1175 mm	2155x1055x1175 mm
		ST	1165x1055x1360 mm	1660x1055x1360 mm	2155x1055x1360 mm
	H135	LX	1165x1080x1360 mm	1660x1080x1360 mm	2155x1080x1360 mm
<b>Peso (netto)</b> Weight (net)	H117	ST	195 kg	224 kg	252 kg
		ST	200 kg	230 kg	260 kg
	H135	LX	200 kg	230 kg	260 kg
<b>Refrigerazione</b> Refrigeration			<b>Ventilata</b> Ventilated		
<b>Refrigerante</b> Refrigerant			R290		
<b>Sbrinamento</b> Defrost			<b>Fermata compressore</b> Off cycle		
<b>Temperatura prodotto</b> Product temperature			-1/+10 °C		
<b>Classe climatica</b> Climate class	H117	ST	3		
		ST	3		
	H135	LX	3		
<b>Condizioni ambientali</b> Operating conditions			25 °C / 60 %RH		
<b>Classe energetica</b> Energy class					

**DATI ELETTRICI - Modelli con unità condensatrici a bordo - condensazione ad aria**  
ELECTRICAL DATA - Models with on-board condensing units - air condensing

<b>Compressore (q.tà - tipologia)</b> Compressor (q.ty - type)	<b>1 Ermetico</b> Hermetico			
<b>Alimentazione</b> Power supply	230 V / 1 Ph / 50 Hz			
<b>Assorbimento elettrico (regime)</b> Electrical input (nominal)	420 W / 3 A	650 W / 3,6 A	850 W / 4,7 A	
<b>Assorbimento elettrico (sbrinamento)</b> Electrical input (defrost)	86 W / 0,5 A	86 W / 0,5 A	105 W / 0,7 A	

**ALLESTIMENTO**  
SETUP

<b>Vasca espositiva</b> Display			
<b>Vassoio pasticceria</b> Pastry Tray	1046x800 mm	1541x800 mm	2036x800 mm
<b>Mensola</b> Shelf	1034x240 mm	1529x240 mm	2024x240 mm

ST - H117

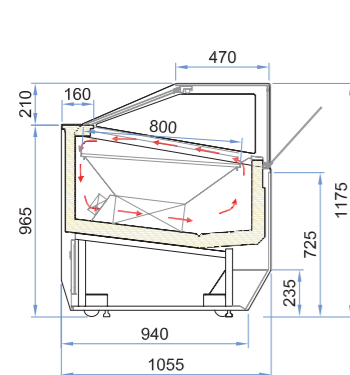

ST - H135

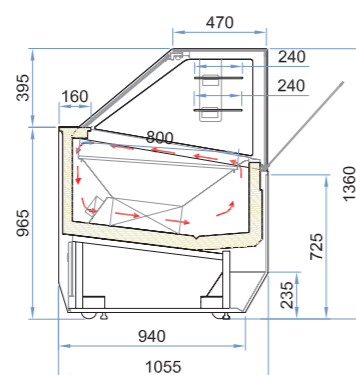

LX - H135

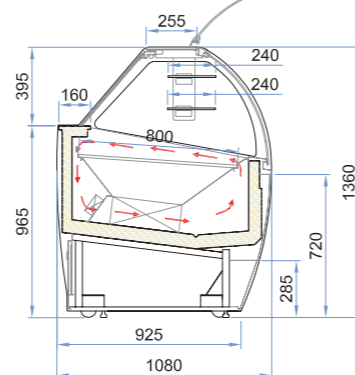

Pastry LX - H135

Gelato LX - H135